

MicroTCA Shelf User's Manual



Product Number:
MTCA4RU-XA

Rev.	Date updated	Change
D1.0	April 14, 2009	Draft Release

Impressum:

Schroff GmbH

D-75334 Straubenhardt, Germany

The details in this manual have been carefully compiled and checked - supported by certified Quality Management System to EN ISO 9001/2000

The company cannot accept any liability for errors or misprints. The company reserves the right to amendments of technical specifications due to further development and improvement of products.

Copyright © 2009

All rights and technical modifications reserved.

Table of Contents

1	Safety	1
1.1	Safety Symbols used in this document	1
1.2	General Safety Precautions	1
1.3	References and Architecture Specifications	2
1.4	Product Definition	2
2	Hardware Platform	2
2.1	Front an Rear View	3
2.2	ESD Wrist Strap Terminals	3
3	Backplane	4
3.1	Backplane Topology	4
3.2	Fabric Interface	5
3.2.1	Common Options	5
3.2.2	Fat Pipe	5
3.2.3	Extended Fat Pipe	5
3.3	Synchronization Clock Interface	5
3.4	Intelligent Platform Management Bus (IPMB)	5
3.4.1	IPMB-L	5
3.4.2	IPMB-0	5
3.5	JTAG	5
3.6	Carrier FRU SEEPROM	6
3.7	Carrier Number	6
3.7.1	Mechanical DIP Switch	7
3.7.2	Electronic DIP Switch (factory default)	7
3.8	Cooling Unit Connectors	8
4	Air Filter	9
4.1	Introduction	9
4.2	Air Filter Replacement	9
4.3	Air Filter Presence Sensor	9
5	Cooling Units	10
5.1	Cooling Unit Connectors and Indicators	11
5.2	Cooling Unit IPMB Addresses	12
5.3	Fan Controller Block Diagram	12
5.4	Serial Interface	12
6	Technical Data	13
6.1	Shelf Dimensions	14
6.2	Terms and Acronyms	15

1 Safety

The intended audience of this User's Manual is system integrators and hardware/software engineers.

1.1 Safety Symbols used in this document

	<p>Hazardous voltage!</p> <p><i>This is the electrical hazard symbol. It indicates that there are dangerous voltages inside the Shelf.</i></p>
---	---

	<p>Caution!</p> <p><i>This is the user caution symbol. It indicates a condition where damage of the equipment or injury of the service personnel could occur. To reduce the risk of damage or injury, follow all steps or procedures as instructed.</i></p>
---	--

	<p>Danger of electrostatic discharge!</p> <p><i>The Shelf contains static sensitive devices. To prevent static damage you must wear an ESD wrist strap.</i></p>
---	--

1.2 General Safety Precautions

	<p>Warning!</p> <p><i>This equipment is intended to be accessed, to be installed and maintained by qualified and trained service personnel only.</i></p>
---	---

- Service personnel must know the necessary electrical safety, wiring and connection practices for installing this equipment.
- Install this equipment only in compliance with local and national electrical codes.
- For additional information about this equipment, see the PICMG MicroTCA Specification (www.picmg.com).

1.3 References and Architecture Specifications

- PICMG® MicroTCA® Base Specification
(www.picmg.com)
- PICMG® AMC® Base Specification
(www.picmg.com)

1.4 Product Definition

The Schroff **MTCA4RU-XA** is a 4 U MicroTCA Shelf, 12+2+2 slot for AMC Single mid-size modules.

2 Hardware Platform

The Schroff MicroTCA Shelf implements the following features:

- Compliant to PICMG MicroTCA Base specification
- Shielded steel case with 19" rack mounting brackets
- MicroTCA Backplane with radial IPMI-L from both MCH slots to all AMC slots and bused IPMB-0 among MCHs, PMs and CUs.
- The Shelf provides:
 - 12 AMC Single mid-size slots
 - 2 redundant MicroTCA Carrier Hub (MCH) slots (Single Full-size)
 - 2 Power Module (PM) slots (12 HP Single)
- Active cooling through two hot-swappable Cooling Units (CUs) providing each:
 - 3 temperature controlled 12 VDC fans.
 - Cooling Unit Enhanced Module Management Controller (CU EMMC)
 - Display Module
- Front accessible air inlet filter

2.1 Front and Rear View

Figure 1: Front View

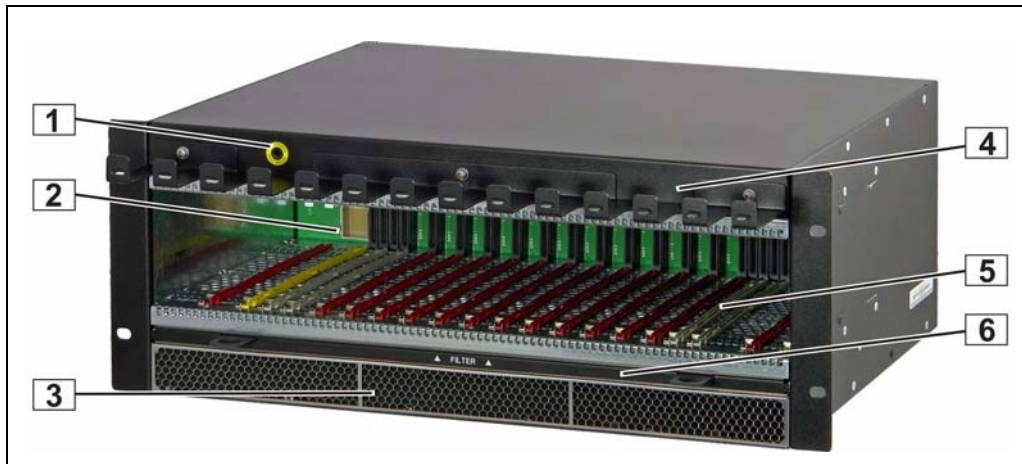

12909800

- | | | | |
|---|--------------------------|---|----------------------------|
| 1 | ESD Wrist Strap Terminal | 4 | Cable Tray |
| 2 | MicroTCA Backplane | 5 | Card Cage with Guide Rails |
| 3 | Air Intake | 6 | Air Filter |

Figure 2: Rear View



12909801

- | | | | |
|---|--------------------------|----|-----------------|
| 7 | Cooling Unit 1 | 9 | Cooling Unit 2 |
| 8 | ESD Wrist Strap Terminal | 10 | Ground Terminal |

2.2 ESD Wrist Strap Terminals



Danger of electrostatic discharge!

Static electricity can harm delicate components. You must wear an ESD wrist strap before exchanging any part or electric component!

The ESD Wrist Strap Terminals (4 mm banana jack) are located at the front and rear side.

3 Backplane

The 12+2+2 slot MicroTCA Backplane provides:

- 12 AMC Single mid-size slots (6 HP)
- 2 MicroTCA Carrier Hub (MCH) slots (6 HP)
- 2 Power Module (PM) slots (12 HP)
- 2 Connectors for Cooling Units

3.1 Backplane Topology

Figure 3: Backplane Topology

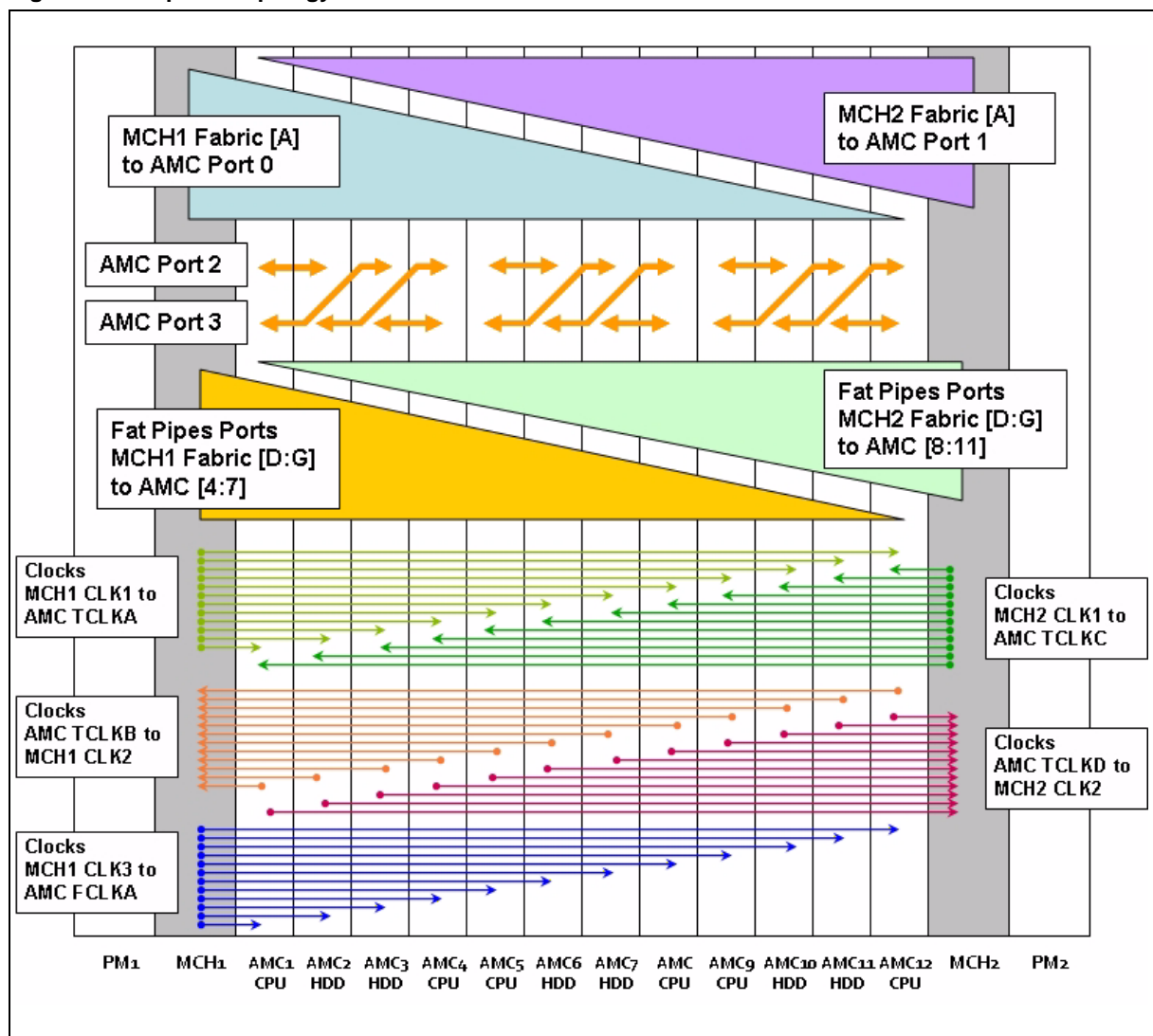

12909802

3.2 Fabric Interface

3.2.1 Common Options

MCH1 Fabric Port A is routed to all AMC slots Port 0 in a radial configuration.

MCH2 Fabric Port A is routed to all AMC slots Port 1 in a radial configuration.

AMC Ports 2 and 3 are direct slot to slot connections to support CPU/HDD configurations.

3.2.2 Fat Pipe

MCH1 Ports [D:G] are routed to all AMC slots Port [4:7] in a radial configuration.

3.2.3 Extended Fat Pipe

MCH2 Ports [D:G] are routed to all AMC slots Port [8:11] in a radial configuration.

3.3 Synchronization Clock Interface

Synchronisation clock topology in accordance with AMC.0 R2.0, especially for the use of PCIe AMC modules in accordance with AMC0 R2.0 that expect the FabricCLK on FCLKA.

Fully redundant telecom clock architecture with TCLKA, TCLKB, TCLKC, TCLKD.

3.4 Intelligent Platform Management Bus (IPMB)

MicroTCA uses an Intelligent Platform Management Bus (IPMB) for management communications.

3.4.1 IPMB-L

The IPMB among AdvancedMCs and the MCHs is non-redundant and implemented in a radial topology. This IPMB called Local IPMB (IPMB-L)

3.4.2 IPMB-0

The IPMB among the MCH, the PM and the CU is called IPMB-0. The reliability of the IPMB-0 is improved by the addition of a second IPMB, with the two IPMBs referenced as IPMB-A and IPMB-B.

The IPMB-A and IPMB-B are routed in a bused configuration.



IPMB-A and IPMB-B are electrically and logically separate from the Local IPMB (IPMB-L)

3.5 JTAG

JTAG signals are not supported.

3.6 Carrier FRU SEEPROM

Two SEEPROMS are located at the backside of the Backplane. The SEEPROMS are connected to both MCHs through I²C-busses.

The I²C-addresses of the SEEPROMs is 0xa4.

3.7 Carrier Number

Figure 4: Electronic and mechanical DIP Switch

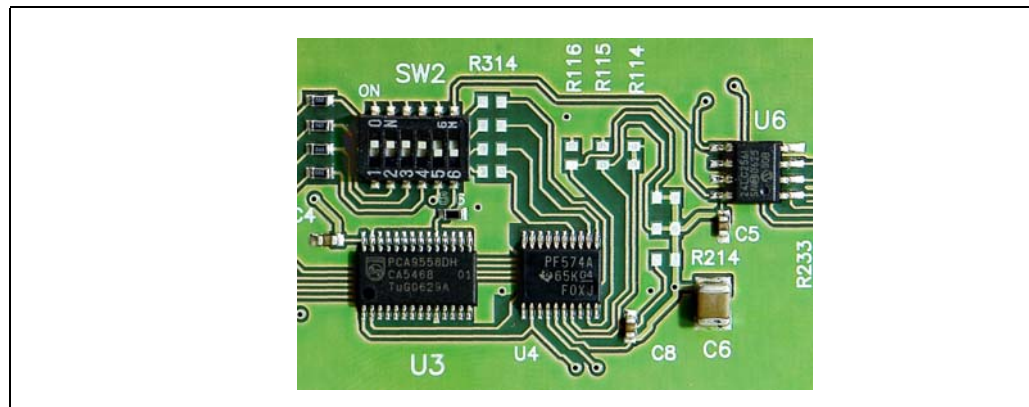

12908801

Each MicroTCA Carrier shall have a unique Carrier Number, ranging from 1 to 16 in its MicroTCA Shelf. To provide the Carrier Number, a mechanical and electronic (PCA9558) DIP switch and a PCF8574A I²C I/O expander is located on the Backplane.

Figure 5: Carrier Number Switches

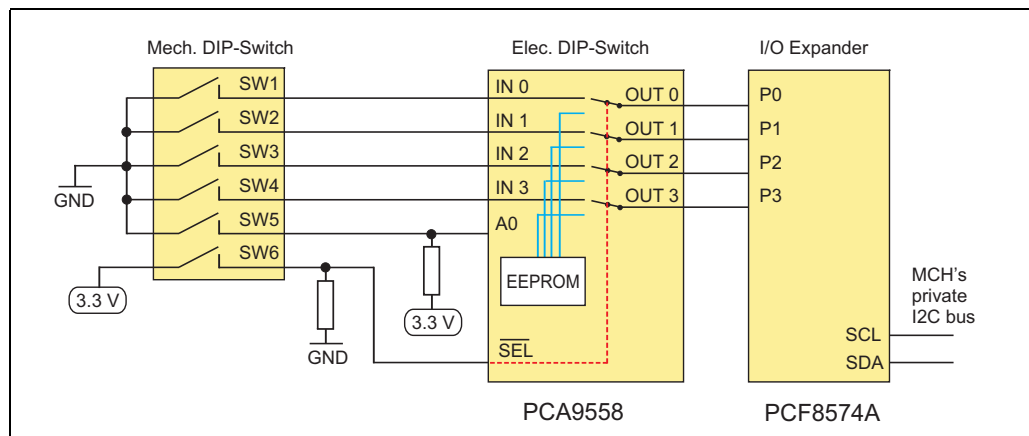

12807826

The customer can use either the mechanical or the electronic DIP switch to set the carrier number.

3.7.1 Mechanical DIP Switch

The mechanical DIP switch is a 6-position switch.

- Switch 1 to 4 are used to set the carrier number (Switch 1 = Bit 0).
- Switch 5 is used to change the I2C-address of the electronic DIP switch.
 - Switch 5 ON: address = 9C
 - Switch 5 OFF: address = 9E
- With switch 6 you can select between mechanical or electronic DIP switch to set the carrier number.
 - Switch 6 ON: Mechanical DIP switch active
 - Switch 6 OFF: Electronic DIP switch active



Two DIP Switches (for redundancy) are located on the Backplane. They are user-accessible after removing the cooling units.

*When setting the carrier number with the **mechanical** DIP switch please note:*

*Switch ON = logic 0
Switch OFF = logic 1*

The mechanical DIP switch is connected to the input of the electronic DIP switch. When the SEL signal is a logic 0, the electronic DIP switch will select the data from the internal EEPROM to drive the output pins, when the SEL signal is a logic 1, the electronic DIP switch will select the signal from the mechanical DIP switch to drive on the output pins.

3.7.2 Electronic DIP Switch (factory default)

The electronic DIP switch is connected to the lower four bits of the I/O lines of the PCF8574A I²C I/O expander. The I/O expander connects to the MCMC's private I²C bus. The MCMC reads the DIP switch setting from the I/O expander, **adds one**, and uses the result as its Carrier Number.



In the default factory setting the electronic DIP switch is active at the address 0x9E (SW5 and SW6 at the mechanical DIP switch = OFF)

Default carrier address = 1 (Data content EEPROM = 0000)

Table 1: I²C Addresses

PCA 9558 DIP switch	0x9e or 0x9c
PCF8574A I/O expander	0x3e

To change the carrier number with the electronic DIP switch you have to send the following I2C command to the electronic DIP switch's EEPROM:

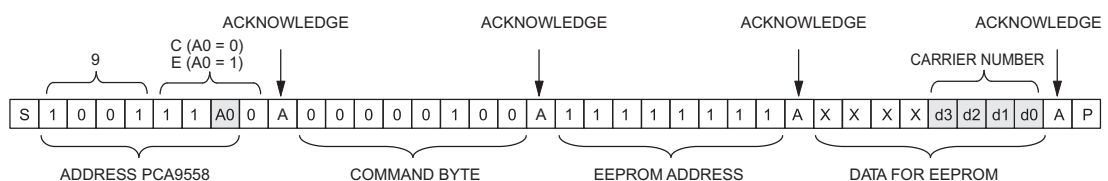

3.8 Cooling Unit Connectors

Two connectors for intelligent Cooling Units are located on the upper and lower side of the Backplane.

Table 2: Cooling Unit Connector Pin assignment

PIN	A	B	C
1	+12 V	+12 V	+12 V
2	+12 V	+12 V	+12 V
3	+12 V	+12 V	GND
4	GND	GND	GND
5	3.3 V MP	CU_ENABLE	CU_PRESENT
6	IPMB0_SCL_A	IPMB0_SDA_A	IPMB0_SCL_B
7	IPMB0_SDA_B	GA0	GA1
8	GA2	GND	GND
9	GND	GND	GND
10			
11			GND
12	GND	GND	GND
13	Air Filter Present	GND	GND
14			
15			
16			

4 Air Filter

Figure 6: Air Filter



12909803

- | | | | |
|---|----------------|---|--------------------------|
| 1 | Filter Element | 3 | Filter Tray |
| 2 | Handle | 4 | Spring mounted ball lock |

4.1 Introduction

The MicroTCA Shelf provides a front replaceable air filter.

The filter meets the following standards and classifications:

- UL 900 Class 2, UL94 HF-1
- Telcordia NEBS GR-78-CORE
- Telcordia NEBS GR-63-CORE

4.2 Air Filter Replacement

The air filter can be removed by pulling the air filter's handles. To re-install, push the air filter into the guide rails at each side of the shelf until the spring mounted ball lock engage.



When installing the air filter, the filter element must be in top position

4.3 Air Filter Presence Sensor

The air filter presence is detected by a reed switch located on the Backplane. The reed switch is activated by a magnet at the rear side of the air filter metal frame. The signal of the air filter presence sensor is hosted by the Cooling Units.

5 Cooling Units

The MicroTCA Shelf provides two rear-pluggable Cooling Units. Each Cooling Unit contains three 12 VDC fans (173 m³/h (102 cfm) each) and a Schroff Cooling Unit Enhanced Module Management Controller (CU EMMC). The CU EMMC has a Enhanced Module Management Controller (EMMC) onboard that communicate with the Carrier Manager over IPMB-0. The CU EMMC controls the fan speed, monitors the air filter sensor and provides hot-swap functionality.

Figure 7: Cooling Unit

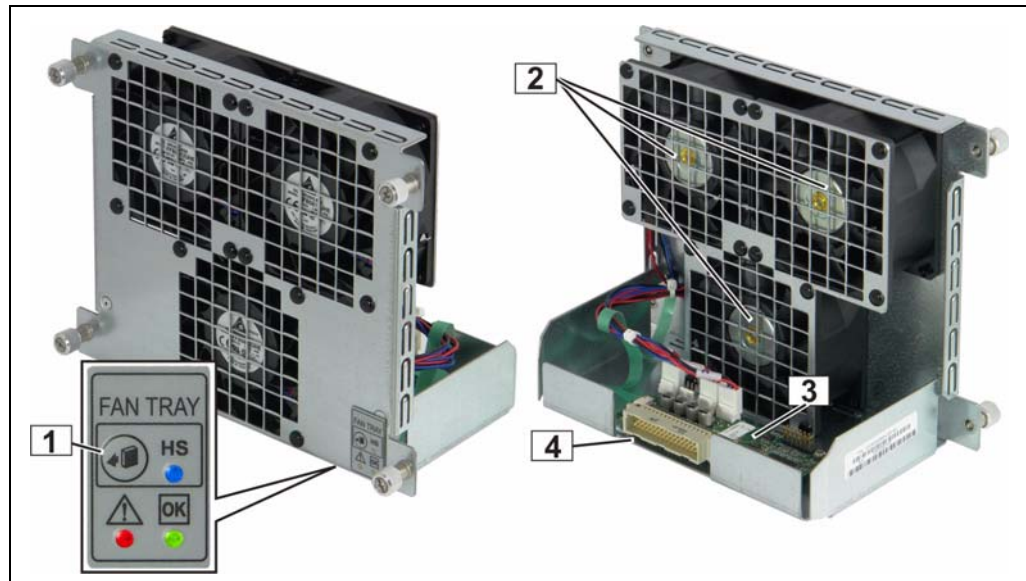

12909805

- | | | | |
|---|-----------------|---|---------------------|
| 1 | Hot Swap Switch | 3 | CU EMMC |
| 2 | Fans | 4 | Backplane Connector |

Figure 8: Airflow

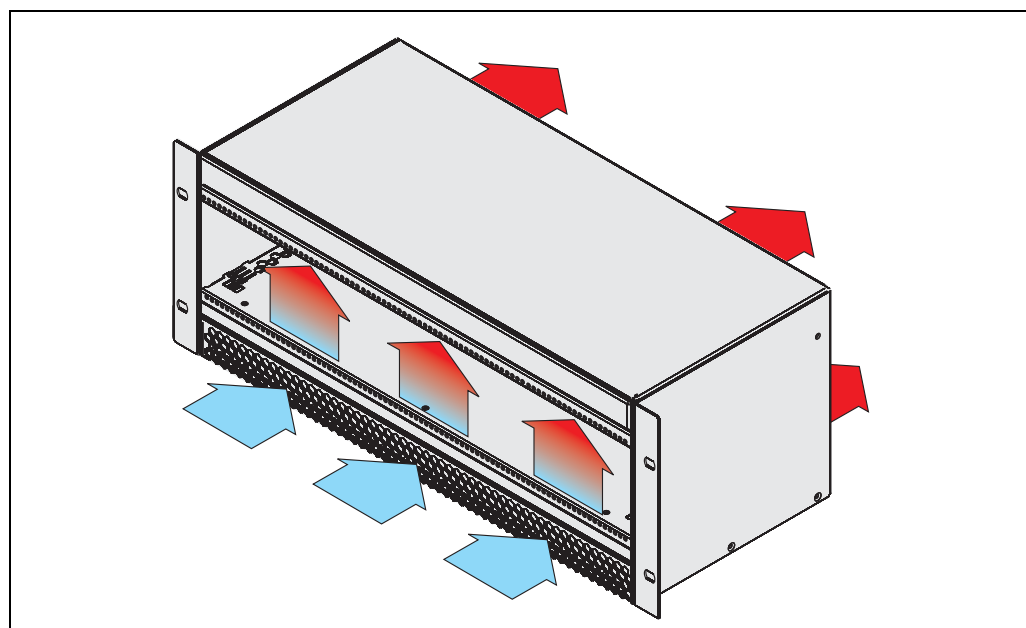

5.1 Cooling Unit Connectors and Indicators

The display module at the cooling unit provides:

- A green LED – “In-Service”
- A red LED – “Out of Service”
- A blue LED – “Hot-Swap”
- A hot-swap switch

The hot-swap switch indicates to the MCH that the Cooling Unit is about to be removed. Once the operator pushes the hot-swap switch, the MCH is informed of the pending extraction. When the MCH feels it is “safe” to remove the Fan Tray, the blue Hot-Swap LED illuminates solid.

Table 3: LEDs on Fan Tray front panel

Color	Description	Status	Condition
Green	In-Service LED	Off Solid green	No Power to the Fan Tray Normal Operation
Red	Alarm LED	Solid red	Attention Status (error condition)
Blue	Hot Swap LED	Off Short blink Solid blue	In use Preparing for extraction Ready to remove

Figure 9: Fan Controller Backplane Connector

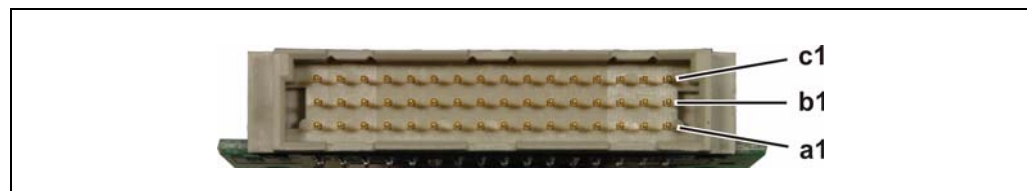

12807804

Table 4: Cooling Unit Connector Pin assignment

PIN	A	B	C
1	+12 V	+12 V	+12 V
2	+12 V	+12 V	+12 V
3	+12 V	+12 V	GND
4	GND	GND	GND
5	3.3 V MP	CU_ENABLE	CU_PRESENT
6	IPMB0_SCL_A	IPMB0_SDA_A	IPMB0_SCL_B
7	IPMB0_SDA_B	GA0	GA1
8	GA2	GND	GND
9	GND	GND	GND
10			
11			GND
12	GND	GND	GND
13	Air Filter Present	GND	GND
14			
15			
16			

5.2 Cooling Unit IPMB Addresses

Table 5: Cooling Unit IPMB Addresses

Cooling Unit 1	0xA8
Cooling Unit 2	0xAA

5.3 Fan Controller Block Diagram

Figure 10: Fan Controller Block Diagram

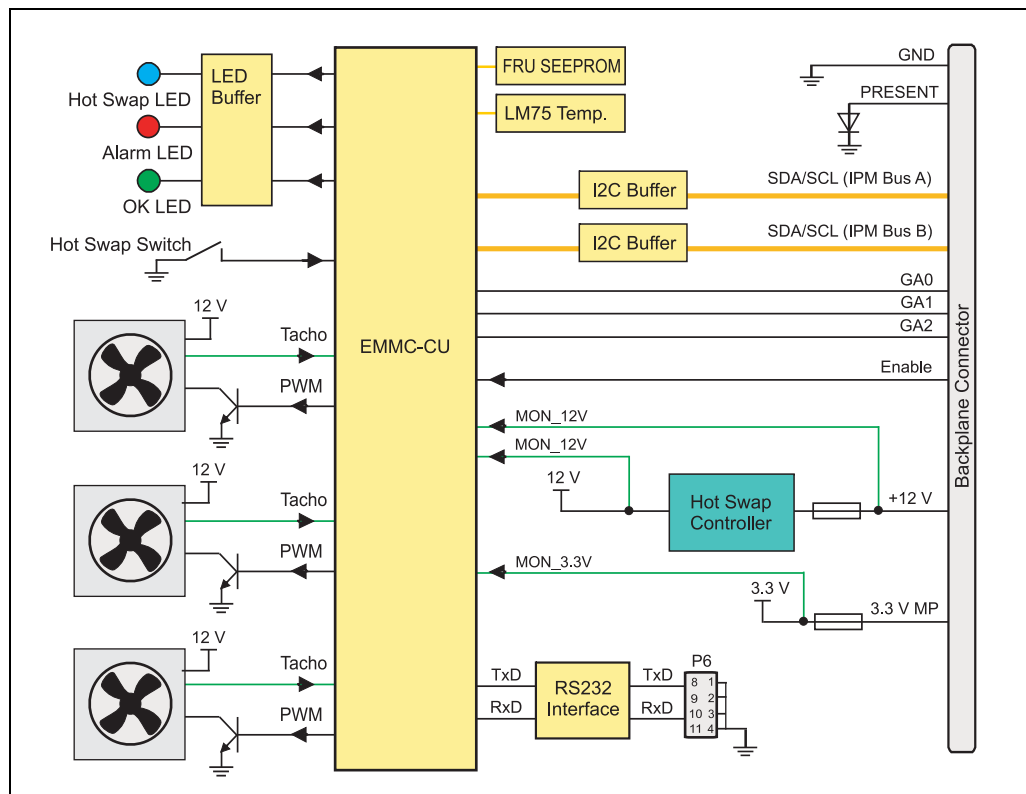

12909806

5.4 Serial Interface

A serial interface for debugging and firmware update is implemented on the fan controller.

Table 6: Serial Interface Connector Pin Assignment

Pin	Signal
1	TxD
3	RxD
2,4,6,8,10	GND

6 Technical Data

Table 7: Technical Data

Physical Dimensions	
Height	177.00 mm
Width (with mounting brackets)	482.60 mm
Depth	295 mm
Depth (with front cable tray)	346 mm
Weight	
Weight completely assembled	9 Kg
Environmental	
Ambient temperature	+5°C...+45°C
Humidity	+5%...+85%, no condensation
EMI	
Conducted Emissions	EN 55022 Class B
Radiated Emissions	EN 55022 Class B

6.1 Shelf Dimensions

Figure 11: Shelf Dimensions

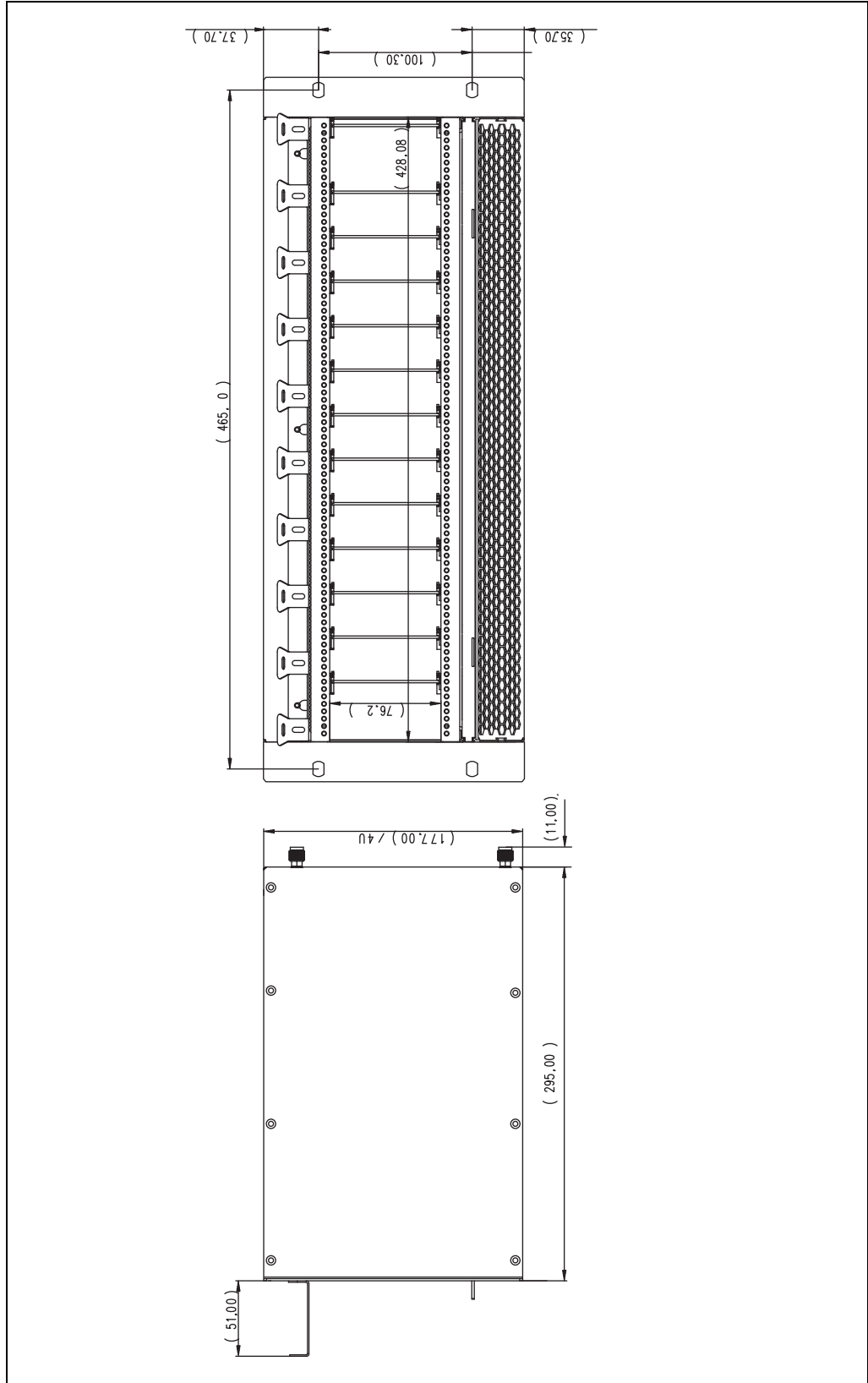

12909807

6.2 Terms and Acronyms

Table 8: Terms and Acronyms

AMC	Advanced Mezzanine Card. AMC defines a modular card that extends the functionality of a Carrier board. Often referred to as mezzanines, these cards called also „AMC Modules.
Backplane	An interconnecting device with connectors, allowing Modules to plug into it
Board	An electronic assembly usually consisting of components mounted on a printed circuit
Card Guide	A mechanical component that provides for the AdvancedMC guidance feature in a Slot
Carrier Local Address	The combination of Site Type and Site Number that uniquely identify a Module within a MicroTCA Carrier
Carrier Manager	A logical function that manages and controls the AdvancedMC Modules, OEM Modules, PMs, and CUs in a MicroTCA Carrier through a set of signals controlled by the PMs together with the IPMB links
Carrier Number	A value to uniquely identify a MicroTCA Carrier within a Shelf
Channel	A group of up to four Ports in the Fat Pipes region which are logically grouped together via E-Keying to define the physical traces of a Link between Link partners. Multiple Channels can be aggregated for a wider Link.
Channel ID	An index into the list of AMC Channels that are defined on an MCH or on a Module
CO	Central Office
Common Options Region	The low order portion of the AdvancedMC Lane mappings, where Lanes are defined as common control fabric interfaces. MicroTCA uses these as a basic interconnect between the AdvancedMCs and MCHs.
Contact List	Defines the use of each contact. Directed signals appear in the lists differently, as applicable to the respective viewpoint of the Module and the MicroTCA Backplane.
Cooling Unit (CU)	A subassembly including fans or blowers to move air to cool a MicroTCA Shelf and related support electronics
CU	See Cooling Unit
Cube	A MicroTCA packaging option where AdvancedMCs, MCHs, PMs, cooling, and mechanical elements are all packaged in a small, roughly cubic enclosure that is approximately 200 mm or 8 in. on a side
Double-Width Slot	Mounting location on a MicroTCA Shelf for a Full-Height or Half-Height Double-Width Module. Double-Width Slots may be created by removing a Strut and Card Guide between two Single-Width Slots.
Double-Width Module	A Module that is roughly twice the width of a Single-Width AdvancedMC Module. Double-Width AdvancedMCs measure approximately 150 mm wide.
EIA	Electronic Industry Association
Electronic Keying or E-Keying	Abbreviation for Electronic Keying. Electronic Keying defines the process in which a MicroTCA Shelf determines if the Control and Fabric interfaces on a Module are compatible with the MicroTCA Shelf interconnects and the other Modules they reach.
EMC	Electromagnetic Compatibility is the condition that prevails when telecommunications (communication-electronic) equipment is collectively performing its individual designed functions in a common electromagnetic environment without causing or suffering unacceptable degradation due to electromagnetic interference to or from other equipment/ systems in the same environment.
EMC Gasket	An electrically conductive elastic stripe mounted to defined edges of the Face Plate providing EMC closure around the AdvancedMC Slots
EMMC	Enhanced Module Management Controller, used on Cooling Units, Power Module, and OEM Modules. See Module Management Controller (MMC).
ESD	Electrostatic Discharge
ETSI	European Telecommunications Standards Institute
Extended Region	The high order portion of the AdvancedMC Lane mappings that are typically used to carry special or high speed data streams. MicroTCA uses the Extended Region to provide high bandwidth interconnects beyond what can be carried on the Common Options Region or Fat Pipes region.
Fabric Interface	The set of MCH Fabric Channel interfaces that provides up to seven Fabric Channels to the AdvancedMCs

Fabric, Fabric Channel	The connection where the MCH is the endpoint of a Slot-to-Slot connection to one-to-four Ports on an AdvancedMC
Face Plate	The front-most element of a Module, attached perpendicular to the PCB, which serves to mount Connectors, indicators, controls, and also seals the front of the Subrack for airflow and EMC
Fat Pipe	A data transmission circuit or network that is capable of carrying large amounts of data without significantly degrading the speed of transmission. The term is derived from the simple plumbing fact that a larger diameter pipe will carry more fluid (or gas) at a greater rate than a smaller one. MicroTCA uses Fat Pipes as high bandwidth interconnects to supplement the Common Options Region.
Frame	An enclosure used for mounting one or more MicroTCA Shelves
FRU	Field Replaceable Unit, any entity that can be replaced by a user in the field
FRU Device ID	A value that uniquely identifies a FRU relative to an IPM Controller. In MicroTCA the most frequent use of FRU Device ID is to uniquely identify a FRU within a MicroTCA Carrier relative to the Carrier Manager.
FRU Information	Data that describes a FRU with an emphasis on data that characterizes the FRU. Format for this data is described in IPMI Platform Management FRU Information Storage Definition and extended herein.
Full-Height Module	Modules that have a Full-Height Face Plate and allow for taller components on Component Side 1 of the Module. Face Plate height is 28.95 mm.
GbE	Gigabit Ethernet (1000BASE-BX)
Gbps	Gigabits (= 1,000,000,000 bits) per second
GBps	Gigabytes (= 1,000,000,000 bytes) per second
Geographic Address (GA)	Identifies the Site Number part of the Carrier Local Address of a Slot in a MicroTCA Carrier via three, three-state signals. Each valid GA combination of the three signals maps to a specific Slot in a MicroTCA Carrier.
HA	High Availability
Half-Height Module	The component height on Component Side 1 of Half-Height Modules is optimized to allow for two stacked Modules to equally split the maximum height (AdvancedTCA pitch) available. The term Half-Height should not be taken literally as being half of a Full-Height Module. Face Plate height is 13.88 mm.
Hot Swap	To remove a component (e.g., an AdvancedMC Module) from a system (e.g., an MicroTCA Shelf) and plug in a new one while the power is still on and the system is still operating
Hot Swap Switch	A switch that is integrated with the Module Latch Mechanism so that its state reflects the state of the Latch. The Hot Swap Switch is disconnected when the Module Handle is fully inserted.
HP	Horizontal Pitch. A measure of Module-to-Module spacing equaling 0.2 in.
Intelligent FRU	A FRU containing a management controller. Intelligent FRUs include the Advanced-MCs, MCHs, CUs, PMs, and OEM Modules, etc.
IPMB	Intelligent Platform Management Bus. The lowest level hardware management bus as described in the Intelligent Platform Management Bus Communications Protocol Specification.
IPMB-0	A dual redundant IPMB that connects MCMCs and EMMCs in a MicroTCA Carrier. Electrically and logically separate from the Local IPMB (IPMB-L).
IPMB-A, IPMB-B	Intelligent Platform Management Buses A and B, respectively. Refers to the two redundant IPMBs that aggregate into IPMB-0.
IPMB-L or Local IPMB	Connects AdvancedMC's MMC with the MCH's MCMC. Electrically and logically separate from the MCMC's IPMB-0.
IPMI	Intelligent Platform Management Interface. A specification and mechanism for providing inventory management, monitoring, logging, and control for elements of a computer system as defined in Intelligent Platform Management Interface Specification.
JTAG	Formally, Joint Test Action Group, an organization that proposed adoption of a specification for a test access port and boundary-scan architecture. Informally, but commonly, the standard, namely IEEE Std 1149.1, that arose from the efforts of the Joint Test Action Group.
JTAG Switch Module (JSM)	A Module that controls the distribution of JTAG signaling to the AdvancedMCs and MCHs within a MicroTCA Carrier

Keying Block	Mechanical entity installed on the backplane used to allow full insertion of Modules that comply with specific mating requirements related to optional Auxiliary Connectors and prevent full insertion of Modules that don't comply
Lane	1. A set of differential signal pairs, one pair for transmission and one pair for reception. One or more Lanes operate together to form a Link 2. E-Keying definition of a differential pair associated with a specific Fabric Link (e.g., a Link generally consists of Lanes[x:0])
Ground, or GND	The reference potential for logic signaling and local power distribution on the MicroTCA Shelf and on the Module
MAC	Media Access Control
Managed FRU	Either an Intelligent FRU or a FRU that is represented by an Intelligent FRU via a FRU Device ID
Management Power (MP)	The 3.3 V power for a Module's management function, individually provided to each Slot by the MicroTCA Shelf
Management Power Channel	An independently managed electrical path that carries Management Power to a Module from a bulk power source
MCH	See MicroTCA Carrier Hub
MCH Crossover Channel	An interface between two MCHs used for implementation-defined communication
MCH Update Channel	An interface between two MCHs used to synchronize state information
MCMC	See MicroTCA Carrier Management Controller
MicroTCA	This specification, governing the application of AdvancedMCs directly on a Backplane. Although not preferred, it is also acceptable to abbreviate it uTCA or iTCA.
MicroTCA Carrier	A group of functions conforming to AMC.0 required to properly support up to twelve AdvancedMC Modules connected together via a common Backplane. The MicroTCA Carrier functions include: power regulation and distribution, hardware platform management, fabric connectivity and optionally clock distribution and JTAG test control.
MicroTCA Carrier Hub (MCH)	An assembly providing MicroTCA Carrier functions needed to support up to twelve AdvancedMCs including MCMC, optional ShMC, optional Fabric switch, and clock.
MicroTCA Carrier Management Controller (MCMC)	Management controller on the MCH. The required management controller that interfaces to AdvancedMC MMCs via IPMB-L and to CU, PM, and OEM Module EMMCs via IPMB-0.
MMC	The required management controller on an AdvancedMC Module which interfaces to the MicroTCA Carrier Manager on the MCH via IPMB-L Module Refers to any MicroTCA Module types, including CU, PM, MCH, OEM Module, or AdvancedMC
Module EMC Gasket	Compressible woven EMC material along the left hand side and the bottom of the Module
Module Handle	Hand grip that is connected to the Module Latch Mechanism, provides user interface that initiates Hot Swap sequence and Module removal
Module Latch Mechanism	Mechanism to hold the Module locked in the Slot with the Module in contact with the bottom of the Slot. The Module Latch Mechanism also provides coupling to the Hot Swap Switch.
Module LEDs	The collective name for the following LEDs available at the Module Face Plate: BLUE LED, LED 1, LED 2, LED 3
MP	See Management Power
MTBF	Mean Time Between Failure(s)
NEBS	Network Equipment Building Systems. A specification published by Telecordia governing the environmental characteristics of telecommunications equipment.
Payload	The primary function that a FRU provides. This includes all the hardware on the FRU except that associated with management. It may also include the firmware, operating system and application software running on the Payload hardware.
Payload Interface	The interface, usually local to the Module, between an (E)MMC and its Payload
Payload Power	The nominal 12 V supply power, individually provided to each Slot by the MicroTCA Shelf for the payload function of the Module
Payload Power Channel	An independently managed electrical path that carries Payload Power to a Module from a bulk power source

PICMGÆ	PCI Industrial Computer Manufacturers Group (PICMG). An industry standards body responsible for the creation of specifications such as AdvancedTCA, AdvancedMC, and MicroTCA.
PM	See Power Module
Port	A set of differential signal pairs, one pair for transmission and one pair for reception
Power Channel	A FRU connection to the Power Subsystem, consisting of Payload Power, Management Power, ENABLE# and PS1#
Power Module (PM)	Front accessible Module that controls the power entry, conversion and distribution of 12 V Payload Power to the Modules within a MicroTCA Shelf
Power Module Input Connector	The connector on the PM Face Plate to which input power is connected
Power Module Output Connector	The PM connector that mates with the backplane connector
Power Subsystem	The PMs operating together in a MicroTCA Carrier
Primary PM	The PM that provides primary power for a given power channel
PWR	See Payload Power
Redundant PM	A PM that takes over for any failed Primary PM
RoHS	Restriction of the Use of Certain Hazardous Substances
Sensor Data Record (SDR)	A data structure record that describes the properties of a sensor, management controller or FRU Information device. Defined in IPMI.
Shelf	An electronic assembly consisting of the Subrack, Backplane, Modules, cooling devices, power subsystems, etc. Also historically known as a chassis. Shelves are usually mounted in Frames.
Shelf-Carrier Manager Interface	A logical IPMB between the Shelf Manager and the Carrier Managers
Shelf Ground	The electrical potential of the metal Frame of the system, the Face Plate of the MicroTCA Shelf, and the Face Plate of the Module. It is important for electrical safety.
Shelf Manager	The entity responsible for managing the cooling in a MicroTCA Shelf. It also routes messages between the System Manager Interface and the Shelf-Carrier Manager Interface, provides interfaces to system repositories, and responds to event messages.
Single-Width Module	AdvancedMC Module with a width around 74 mm which fits in a Single-Width AdvancedMC Slot
Slot	The union of a Connector and a Card Guide that defines the position of one AdvancedMC, MCH, Power Module, OEM Module or CU. Slots are similar in concept to the Bays used in the AMC.0 specification. A MicroTCA Subrack typically contains multiple Slots.
Slot Number	Uniquely identifies a Slot within a Shelf
Startup PM	A Power Module selected by the Power Subsystem during power up, to operate in autonomous mode and automatically provide Management Power, asserts ENABLE#, and provide Payload Power to CU and conditionally to MCH Power Channels that are present.
Subrack	A mechanical assembly that provides the interface to Modules, including Advanced-MCs, and consists of the Card Guides, ESD discharge, alignment/keying, Handle interface, Face Plate mounting hardware, EMC Gasketing, and Backplane interface
System Event Log	(SEL) Persistent Storage for events as defined by IPMI
System Manager	A level of management functionality above the Shelf Manager charged with the management of an entire system, whatever that may mean in a specific implementation
System Manager	Interface The communication interface between Shelf Manager and System Manager
Tier	A horizontal row of Modules across a Shelf
Zone 3	A region used for I/O expansion typically above an AdvancedMC Connector within a Slot (standard vertical orientation, viewed from the front)



SCHROFF GMBH

**Langenalberstr. 96-100
D-75334 Straubenhardt**

www.schroff.biz

www.a-tca.com

Tel.: + 49 (0) 7082 794-0

Fax: +49 (0) 7082 794-200