

# DETECTOR SWITCH

## DSJ Serise Pb Free

### ■ Features

1. Ease in switching during rotation while folding/unfolding due to the use of a lever-shaped shaft.
2. Smallest in the industry, measuring only 2.2x3.4x1.5 mm high.
3. As light as 0.3N force sufficient to operate this small detector switch.
4. 90 degree operation angle by the use of a lever shaft.
5. Lead-free solder used.

### ■ Specifications

- |                     |                    |
|---------------------|--------------------|
| 1. Rating           | : 12A 12V DC       |
| 2. Circuit          | : SPST             |
| 3. Operating System | : Non-lock push-on |
| 4. Stroke           | : 1.1mm            |
| 5. Operating Force  | : 0.3N             |
| 6. Operating Life   | : 100,000 cycles   |

### ■ Applications

Cellular phones, PDAs, digital still cameras, portable audio equipment, etc.

### JPS1110-43 F

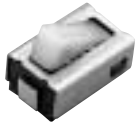

Circuit

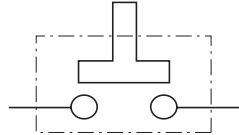

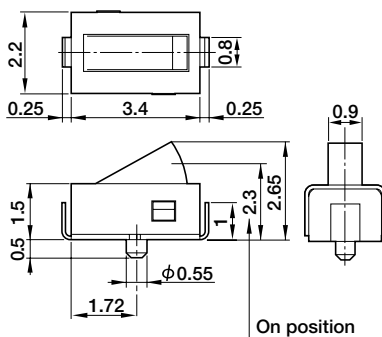

### P.C.Board Dimension

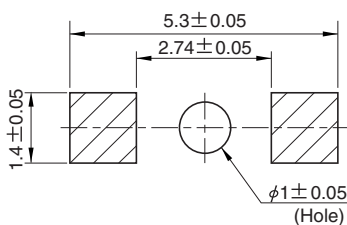

### ■ Packing Style

Packing	Part No.
Pack in Bulk	JPS1110-4301F
Embossed Taping Pack	JPS1110-4311F

### ■ Reel

Part No.	Qty/Reel (pcs)	External Dimension
JPS1110-4311F	2,500	φ 380