

## AdvancedMC module mechanics PIGMG® AMC.0 R2.0 RC1.1

- Kit, shielded
- Locking of modules without screws
- For Conventional, Cutaway and Hybrid Carrier
- Insertion/extraction mechanics in accordance with AdvancedMC standard
- Insertion/extraction mechanics designed for micro switch operation (hot-swap)
- Inclusive of Light Pipes

# NEW

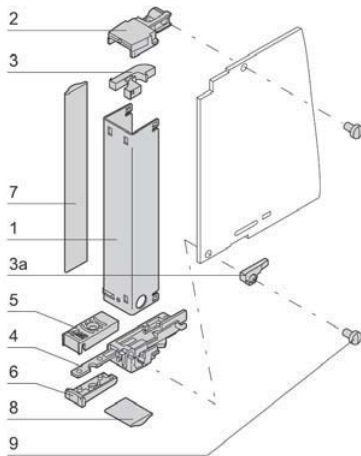

### Delivery comprises (Kit)

Item	Qty	Description
1	1	U-form front panel, stainless steel, 0.6 mm
2	1	Reception for Light Pipe and printed board bracket, Zn die-cast, nickel-plated
3	1	Light Pipe, top, PC, UL 94 V-0
3a	1	Light Pipe, bottom, PC, UL 94 V-0
4	1	Standard insertion/extraction mechanics, with micro switch operation and printed board bracket
5+6	1	Handle, PC, UL 94 V-0, black
7	1	Lateral EMC gasketing, core: foam, sleeve: textile cladding with CuNi coating
8	1	Bottom EMC gasketing, core: foam, sleeve: textile cladding with CuNi coating
9	1	Assembly kit

12806059

### Single AdvancedMC module

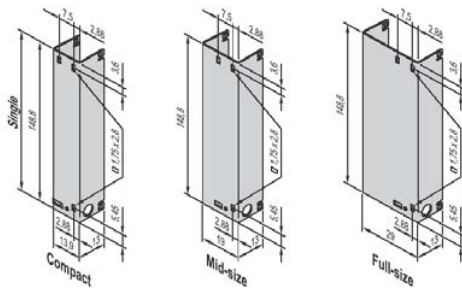

12806057

### Double AdvancedMC module

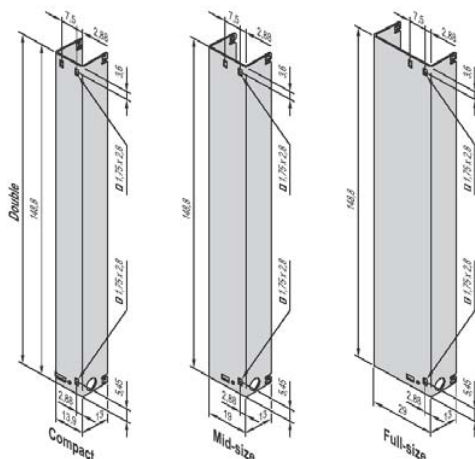

12806055

### Order Information

Description	Order no.
AdvancedMC module mechanics Single Compact, 3 HP	<b>20849-127</b>
AdvancedMC module mechanics Single Mid-size, 4 HP	<b>20849-128</b>
AdvancedMC module mechanics Single Full-size, 6 HP	<b>20849-129</b>
AdvancedMC module mechanics Double Compact, 3 HP	<b>20849-130</b>
AdvancedMC module mechanics Double Mid-size, 4 HP	<b>20849-131</b>
AdvancedMC module mechanics Double Full-size, 6 HP	<b>20849-132</b>
<b>Micro switch for AdvancedMC module (opener)</b> for soldering (SMD), PU 10 pieces	<b>20849-065</b>
<b>Micro switch for AdvancedMC module (closer)</b> for soldering (SMD), PU 10 pieces	<b>20849-015</b>

### Note

- Filler module (filler panel) see page 34
- Description micro switch for AdvancedMC module, see page 35
- Schroff offers an extensive modification service via the Front Panel Service, including customized cut-outs, foils and silk-screen printing, [www.schroff.biz/fpe](http://www.schroff.biz/fpe)

## FRONT PANEL FAST TRACK



For further information [www.schroff.biz/oneclick](http://www.schroff.biz/oneclick)  
oneClick code = Order no.